

INSTALLATION, OPERATION AND MAINTENANCE INSTRUCTIONS

238 - Wellglass Luminaires

ATEX & IECEx

Important: Please read these instructions carefully before installing or maintaining this equipment. Good electrical practices should be followed at all times and this data should be used as a guide only.

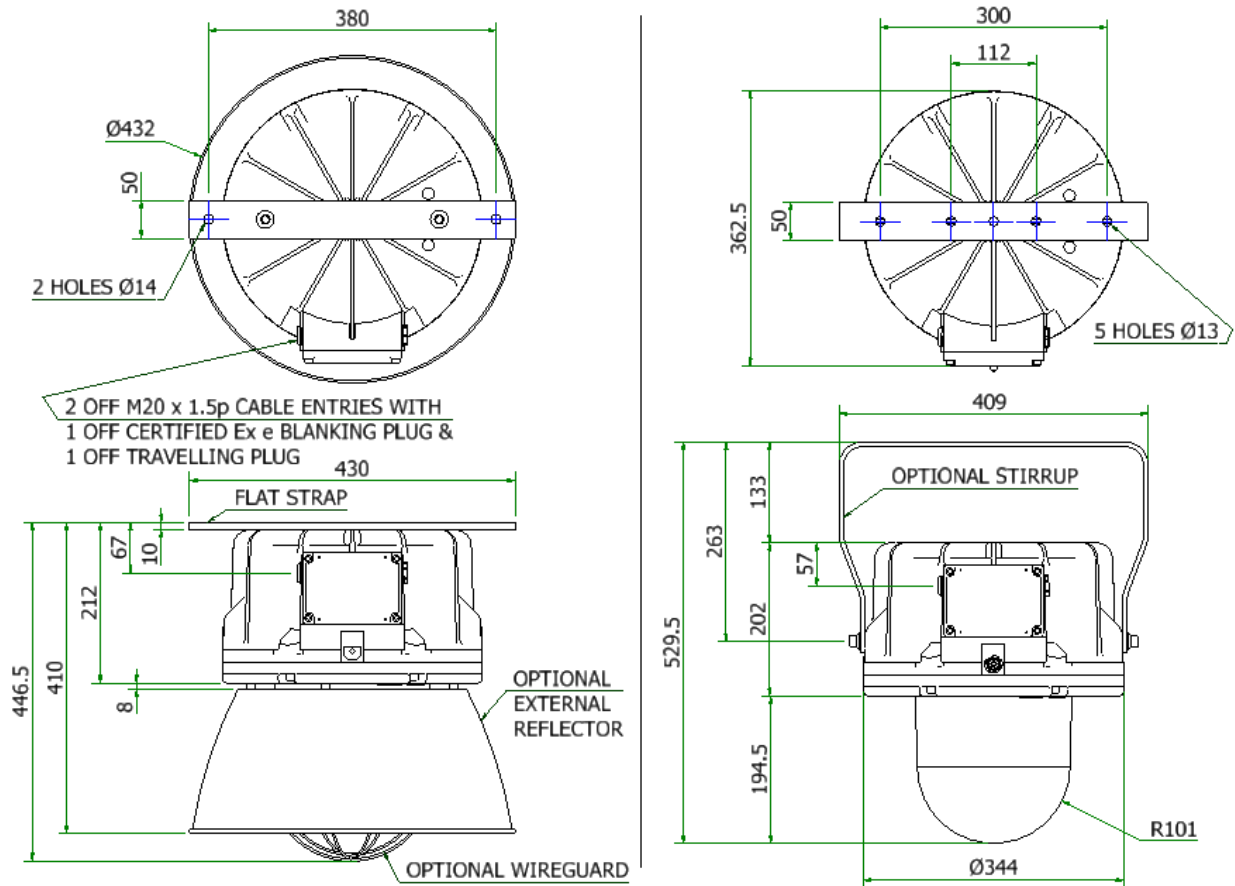

WEIGHT	150W SON/E	250W SON/E
ALUMINIUM	21.6Kg	24.2Kg

WINDAGE AREA : 0.11m ²
WINDAGE AREA WITH OPTIONAL EXTERNAL REFLECTOR : 0.15m ²



0.0 Specification

Type Of Protection	Ex de (flameproof and increased safety), Ex tb (dust)
Protection Standards	(IEC) EN 60079-0, (IEC) EN 60079-1, (IEC) EN 60079-7, (IEC) EN 60079-31.
Area Classification	Zone 1 and Zone 2 areas to (IEC) EN 60079-10-1 Zone 21 and Zone 22 areas to (IEC) EN 60079-10-2
Installation	(IEC) EN 60079-14
Certificate	IECEX Certificate of Conformity IECEX BAS08.0056 EC Type Examination Certificate Baseefa08ATEX0177
Equipment Coding	Ex de IIB T* Gb Ex tb IIIC T*°C Db * IP6X (*T amb see table 0 for details)
ATEX Coding	Ⓜ II 2GD
Ingress Protection	IP66 to EN/IEC 60529
CE Mark	 <p>The CE marking of this product applies to "The Electrical Equipment (Safety) Regulations 2006", "The Electromagnetic Compatibility Regulations 2004", the "Waste Electrical and Electronic Equipment Regulations 2006" and the "Equipment and Protective Systems intended for use in Explosive Atmospheres Regulations 1996". [This legislation is the equivalent in UK law of EU directives 2014/35/EU, 2014/30/EU, 2012/19/EU and 2014/34/EU respectively].</p> <p>The Equipment is declared to meet the provisions of the ATEX directive (2014/34/EU) by reason of the EC Type Examination and compliance with the Essential Health and Safety Requirements. M Poutney Technical Manager</p>
<p>SPECIAL CONDITIONS FOR SAFE USE None</p>	

1.0 Introduction - 238 Wellglass Luminaire.

The type 238 Wellglass Luminaire is designed for all round and high bay applications. It is suitable for use with elliptical discharge lamps. An external reflector is available.

Note: Lamp ranges and temperature ratings are outlined in TABLE 0. The wellglass is certified down to -50°C.

2.0 Storage

Luminaires and control gear boxes are to be stored in cool dry conditions preventing ingress of moisture and condensation. Any specific instructions concerning emergency luminaires must be complied with.

3.0 Installation and Safety

3.1 General

There are no health hazards associated with this product whilst in normal use. However, care should be exercised during the following operations. Installation should be carried out in accordance with EN/IEC 60079-14 or the local hazardous area code of practice, whichever is appropriate, and fitting of specified insulating material to be adhered to where a specific fire resistance rating is required.

In the UK the requirements of the 'Health and Safety at Work Act' must be met.

Handling and electrical work associated with this product to be in accordance with the 'Manual Handling Operations Regulations' and 'Electricity at Work Regulations, 1989'. Your attention is drawn to the paragraphs

- (i) 'Electrical Supplies',
- (ii) 'Electrical Fault Finding and Replacement' and
- (iii) 'Inspection and Maintenance'.

The luminaires are Class 1 and should be effectively earthed.

The luminaires are quite heavy and suitable means of handling on installation must be provided.

Guards can be supplied with or fitted retrospectively to protect glass if there is a higher than normal risk of mechanical damage.

This wellglass luminaire has passed thermal shock testing during certification, it is still advisable to mount the wellglass in locations to reduce the possibility of thermal shock.

Certification details on the rating plate must be verified against the application requirements before installation.

The information in this leaflet is correct at the time of publication. The company reserves the right to make specification changes as required.

3.1.1 Use in Combustible Dust Atmospheres

Where the equipment is used in ignitable dust atmospheres reference must be made to the selection and installation standards in order that the equipment is used correctly. In particular this applies to the de-rating of surface temperature for use where dust clouds may be present. Dust layers should not be allowed to accumulate on the fitting surface and good housekeeping is required for safe operation. Dust in layers has the potential to form ignitable clouds and to burn at lower temperatures.

Refer to EN (IEC) 60079-10-2 & EN (IEC) 60079-14 for additional details of selection and installation.

3.1.2 Hybrid Mixtures – Gas and Dust

Where hybrid mixtures exist as a potentially explosive atmosphere, consideration should be given to verifying that the maximum surface temperature of the luminaire is below the ignition temperature of the hybrid mixture.

3.2 Tools

8, 6, 5mm A/F socket keys.

3mm and 5mm flat blade screwdriver, 19mm A/F spanner.

Suitable spanners for installing cable glands.

Pliers, knife, wire strippers/cutters.

3.3 Electrical Supplies

The supply voltage and frequency should be specified when ordering. A maximum voltage variation of +6%/-6% on the nominal is expected. (The safety limit for T rating is +10%). Luminaires should not be operated continuously at more than +6%/-10% of the rated supply voltage of the control gear or tapping. The user must determine the **actual** underlying site supply and purchase or adjust accordingly. **Care must be taken in connecting to the nominal 230V UK public supply.** In most cases, the luminaire has multi-tapped control gear which can be set to a range of voltages on 50 or 60Hz cycles. The tappings are shown on the control gear and the limits are shown on the rating plate. If the equipment is located in high or low voltage sections of the system, an appropriate voltage tap should be selected, but care must be taken to log or mark the equipment so that the tapping is re-set if the equipment is re-located. If in doubt, tappings should be set on the high side. 20V max. nominal drop is acceptable for MBF, 10V max. drop is desirable for HPS and Metal Halide(MH). The light output will be reduced. The HPS/MH circuits use S.I.P ignitors and the circuit diagram will indicate the choke connections. Where shore or construction site supplies are used, different to the service supplies, tappings should be re-set. If not, advice on the effect of these temporary supplies should be sought from the Technical Department. Where adverse system conditions occur, luminaires can be supplied without PFC. The circuit current will then be the lamp current. The circuit power does not change. Running at over the rated supply voltage will reduce life and at greater than +10% will compromise the T rating.

3.4 Lamps

The lamps used in this range are of a standardised type and there is no preference between makes, or in the case of HPS, colour. The MBI 250W is the 3.0A type. Due to the need to control photometric performance and certification conditions, and avoid incorrect lamps being fitted, the type of lamp and size is specified on the rating plate. If mixed installations are used, care must be taken to ensure that the correct lamp is fitted on installation and replacement.

Mercury vapour lamps will burn for up to 24,000 hours but should be changed at 10,000 as they will then be at about 70% of initial output. HPS/MH lamps substantially maintain their light output to the end of their electrical half life, which again can be up to 24,000 hours. However, lamp replacement at around 16,000 hours is desirable to avoid piecemeal replacement on a large scale. **HPS and MBI lamps should be replaced shortly after they do not light.** One indication of the end of life for HPS lamps is 'cycling' where the lamp goes out then re-ignites after a minute or so interval. If discharge luminaires are burned continuously they should be switched off occasionally, to allow old lamps to fail to re-ignite rather than possibly become diodes with detrimental effects on control gear. The above information is current at the time of publication. The development of lamps and control gear is ongoing and detailed advice on lamp performance can be obtained from the Technical Department or the lamp supplier. **HPS and MBI circuits should not be energised without a lamp fitted.** In general, HPS lamps without internal ignitor should be used. The current HPS control gear is incompatible with internal ignitor lamps. GES (E40) 125W Mercury Vapour lamps should be used as standard.

3.4 Mounting

Luminaires should be installed where access for maintenance is practical and in accordance with any lighting design information provided for the installation. This will usually consist of aiming points and aiming angles.

The top mounting or trunion mounting arrangements should be secured with lock washers or self-locking nuts and bolts.

3.5 Cabling and Cable Glands

3.5.1 Cable Glands

The installer and user take responsibility for the selection of cables, cable glands and seals.

The product is certified for ATEX and to comply with the certification for installation and use within the EU, cable glands and sealing plugs must be ATEX certified. For installation outside the EU, suitable cable glands in accordance with IEC 60079-0 will meet the technical requirements.

Cable glands for entry into Ex e enclosures when fitted with any gland to body sealing method and the supply cable must reliably maintain the IP66 rating of the enclosure. The cable gland must withstand an impact value of 7Nm or 4Nm where the risk of mechanical damage is low.

Sealing plugs must be similarly rated and a tool must be used for their removal. Where the cable is not reliably clamped externally to the apparatus, the cable gland must clamp the cable against a pull in Newtons of 20x the cable OD in mm for non-armoured cable and 80x the cable OD for armoured cable. Selected metal industrial cable glands may meet this requirement. Plastic cable glands must be Ex certified. Glands for metal covered mineral insulated cables must be Ex e certified. Where brass cable glands are used in a corrosive environment nickel plating should be used. Two tapped cable entries are provided, one with a plug and seal suitable for permanent use, the other has a travelling plug. M20 x 1.5 entries are standard, other sizes are available on request.

3.5.2 Cable

At maximum rated ambient temperature refer to rating table for minimum cable temperature rating. The luminaire is also rated with the temperature rise at the cable entry. This allows the user to adjust the cable spec. for an **actual** T amb lower than that for which the luminaire is certified. The standard looping conductor size is 6mm².

Internal and external earth points are provided. For luminaires specified for non-standard ambient temperatures refer to the Technical Department.

300/500V cable ratings are adequate and no special internal construction is necessary as the terminations are Ex e. The selection of cable size will be suitable for the fuse rating. Some guidance on this is given below. When MCB's are used, the type with the higher inrush current resistance, as used for motor starting and lighting, should be specified.

3.5.3 Cable Connection

The cable connections are made by removing the terminal chamber cover. The retaining screws are captive and should be re-greased as required. The conductors should be bared back so that they make full contact in the terminals, but the bare conductor should not be more than 1mm beyond the terminal. Unused terminal screws should be tightened. The core must be identified by polarity and connected in accordance with the terminal markings. Before re-fitting the cover, a final check on the correctness of connections should be made. Cover bolt torque 6Nm. Where control gear tappings need to be re-selected, the lampglass needs to be removed (see below). Undo the three screws and extract the reflector then re-select the taps (see 'Electrical Supplies' above).

3.6 Fitting Lamps

Make sure the correct lamp is selected as detailed above. Access for fitting lamps is gained through the lampglass cover. The lampglass cover assembly should be un-bolted and suspended using suspension chain. During this operation or if the lampglass assembly is removed from the suspension chain, care must be taken to ensure no damage to the glass occurs. Take care not to hang the lampglass on one bolt when removing or replacing. Before removing the lampglass on any occasion, check that the suspension chain is secure and in good condition. The lamp should be firmly screwed into place. The flameproof path should have a coat of silicone grease (Dow Corning "Molykote III" or similar) or other protective non-setting grease suitable for high temperature. Replace all bolts and fully tighten. Torque 16Nm.

3.7 Inspection and Maintenance

Visual inspection should be carried out at a minimum of 12 monthly intervals and more frequently if conditions are severe refer to (IEC) EN 60079-17. The time between lamp changes could be very infrequent and this is too long a period without inspection.

3.7.1 Routine Examination

The equipment must be de-energised before opening and note taken of the rated opening delay periods alternatively the nameplate may read 'do not open when an explosive gas atmosphere is present'. Individual organisations will have their own procedures. What follows are guidelines based on (IEC) EN 60079-17 and on our experience:

- 1 Ensure the lamp is lit when energised and that the lampglass is not damaged. If the glass is damaged it must be replaced. (ref. 3.6 if removing glass assembly).

- 2 When de-energised and left to cool there should be no significant sign of internal moisture. If there are signs of water ingress, the luminaire should be opened up, dried out, and any likely ingress points eliminated by re-gasketing*, re-greasing or other replacement.
- 3 Check the terminal chamber bolts for tightness. Torque 6Nm.
- 4 Check the cable gland for tightness and re-tighten if necessary.
- 5 Check any external earthing.
- 6 Examine the lampglass for any signs of sealant damage, cracking or discoloration. If thought necessary, the silicone weather seal can be re-sealed with a proprietary brand of clear RTV silicone, but only if the underlying sealant is in good condition.
- 7 Check all cover bolts for tightness. Torque 16Nm.
- 8 Check for signs of corrosion between the lampglass cover and the main housing. Evaluation of this will be a matter for judgement gained by experience, as there may be little evidence on the outside. If there is any sign of corrosion, remove the cover and wipe the flameproof paths with a clean cloth and non-metallic scraper. Examine the surfaces for pitting; any pitted component should be replaced. A damaged or non-resilient gasket* must be replaced. The cord is 3mmØ. The cover should be re-greased with silicone (Dow Corning 'Molykote III' or similar) or other non-setting grease suitable for high temperatures, and re-fitted with all bolts fully tightened. Any replacement bolts must be identical to the original. All are 18/8 stainless steel ISO262 grade A4-70. With this type of flameproof path all bolts must be in place and tight. The maximum gap for IIB in this case is 0.2mm. It will be unusual for any luminaire to have a gap of more than 0.1mm when tried with a feeler gauge. If 0.1mm is exceeded, check that no foreign bodies or debris at the bottom of the blind tapped holes is keeping the surfaces apart and, if not, a workshop overhaul should be carried out to bring the apparatus to as new condition. Periodically, when the lampglass is removed, the opportunity should be taken to remove the reflector, check the lampholder connections for signs of over-heating and similarly check the control gear.
- 9 The terminal chamber should be opened periodically and checked for moisture and dirt ingress. The cable connections should be checked for tightness. The gasket* should be checked for cracks or lack of elasticity, and if necessary, replaced. (It may well be practical to also replace the gasket* on each occasion if this is at a 3-year interval). Torque 6Nm.
- 10 If painting operations have taken place around the luminaire, ensure that coatings have not entered the flameproof path or been deposited on the lampglass. If they have, dismantle and clean carefully.
- 11 Check that mountings are secure.
- 12 Cover the bolt heads with silicone grease to prevent corrosion and accumulation of dirt in the screw threads.
- 13 Clean the lampglass.
- 14 If there is suspicion that the luminaire has suffered mechanical damage, a stringent workshop check should be made.

Important: *Where spares are needed, these must be replaced with manufacturer parts. No modifications should be made without the knowledge and approval of the manufacturer.*

* EPDM Gasket not to be fitted below -20°C.

3.8 Electrical Fault Finding and Replacement

The supply must be isolated before opening the luminaire.

With Mercury lamps the faults are simple, loose or broken connections, unserviceable lamps or open circuit control gear. Control gear will not normally go open circuit unless it has overheated first and the signs of this are obvious, being severe discoloration of the paint on the gear and cracks in any exposed insulation. Similarly, a bad contact at the lamp cap will usually result in signs of overheating. Any fault finding must be done by a competent electrician and, if carried out with the luminaire in place, under a permit to work.

With HPS and MBI lamps the ignitor can become faulty. If the lamp is fitted, the choke has continuity and the connections are good and correct, they should produce an 'attempt to start' effect and a buzzing sound from the ignitor. It will be unusual to have no other parts available to perform a substitution fault finding routine and this is the normal procedure. Before re-assembling, all connections should be checked and any damaged cable replaced. The ignition connection to the lampholder is sleeved with H.T. sleeving and this must be kept in place.

4.0 Fuse Ratings

The fuse ratings for HID lamp circuits need to take account of three components of circuit current. Current inrush to PFC capacitors which can be up to 25x the rated capacitor current and last 1-2 milliseconds; lamp starting current including steady capacitor current which together may decline from up to 200% of normal at 10 seconds after switch-on to normal after 4 minutes; rectification effects caused by asymmetrical cathode heating for a few seconds after starting, this effect is random and very variable.

With the availability of MCB's with a wide range of characteristics, the individual engineer can make a better judgement of what is required. Use MCB's suitable for inrush currents to reduce ratings. The normal capacitor current will probably be the

determining factor, 0.076A per μF at 240V 50Hz (adjust for other volts by multiplication, x 6/5 for 60Hz). For HBC fuses use 1.5 x normal capacitor current. All calculations must satisfy wiring regulations.

Note: Starting and running currents for 240V, 50Hz are as indicated in TABLE 1. A conventional matrix for HBC fuses is shown in TABLE 2.

5.0 Disposal of Material

The unit is mostly made from incombustible materials. The capacitor is of the dry film type and does not contain PCB's. The control gear contains plastic parts and polyester resin. The ignitor contains electronic components and synthetic resins. All electrical components may give off noxious fumes if incinerated. Take care to render these fumes harmless or avoid inhalation. Any local regulations concerning disposal must be complied with. Any disposal must satisfy the requirements of the WEEE directive [2012/19/EU] and therefore must not be treated as commercial waste. The unit is mainly made from incombustible materials. The control gear contains plastic, resin and electronic components. All electrical components may give off noxious fumes if incinerated.

5.1 Lamps

Discharge lamps in modest quantities are not "special waste". The outer envelope should be broken in a container to avoid possible injury by fragmentation.

This applies to the UK, there may be other regulations on disposal operating in other countries.

Important: Do not incinerate lamps.



To comply with the Waste Electrical and Electronic Equipment directive 2012/19/EU the apparatus cannot be classified as commercial waste and as such must be disposed of or recycled in such a manner as to reduce the environmental impact.

Tables 0/1/2							
Table 0	Lamp Ranges and Temperature Ratings					Refer to Section :	1.0
Lamp	Wattage	Rated Supply	T Class	T amb °C -50°C to	Dust Rating °C	Cable Rating °C	Cable Rise °C
SON/E	70	(210 to 254V, 50Hz	T4	50	105	70	20
SON/E	70	220 to 270V, 60Hz)	T4	60	125	85	20
SON/E	70	"	T5	40	95	70	20
SON/E	100	"	T4	60	125	80	20
SON/E	100	"	T4	40	105	70	20
SON/E	150	"	T3	55	140	80	30
SON/E	150	"	T4	40	125	70	30
SON/E	250	"	T3	45	150	80	40
MBI	70	"	T4	50	105	70	20
MBI	70	"	T4	60	125	85	20
MBI	70	"	T5	40	95	70	20
MBI	100	"	T4	60	125	80	20
MBI	100	"	T4	40	105	70	20
MBI	150	"	T4	40	140	70	30
MBI	150	"	T3	55	125	80	30
MBI	250	"	T3	45	140	80	40

Alternatively the ambient temperature range may be -20°C or -45°C to above.



Table 1	Starting and Running Currents		Refer to Section :	4.0
Lamp	Start A	Run A	Capacitance μ F	Circuit Power (W)
70W HPS	0.72	0.45	10	85
100W HPS	1.00	0.56	10	114
150W HPS	1.35	0.9	20	175
250W HPS	2.34	1.4	30	286
70W MBI	0.72	0.45	10	85
100W MBI	1.00	0.56	10	114
150W MBI	1.60	0.9	20	175
250W MBI	2.70	1.4	30	286

Note: Minimum power factor correction: 0.85.

Table 2	Fuse Ratings						Refer to Section :	4.0
Lamp	Number of Lamps							
	1	2	3	4	5	6		
70W HPS	4A	4A	4A	6A	6A	10A		
100W HPS	4A	4A	6A	10A	10A	10A		
150W HPS	4A	6A	10A	10A	16A	16A		
250W HPS	10A	16A	16A	20A	20A	20A		
70W MBI	4A	4A	4A	6A	6A	10A		
100W MBI	4A	4A	6A	10A	10A	10A		
150W MBI	4A	6A	10A	10A	16A	16A		
250W MBI	10A	16A	16A	20A	20A	20A		

Chalmit Lighting is a leading supplier of Hazardous Area lighting products

	<p>CHALMIT LIGHTING PO Box 5575 Glasgow, G52 9AP Scotland</p>	

For technical support, please contact: techsupport@chalmit.com

Note: Chalmit Lighting reserves the right to amend characteristics of our products and all data is for guidance only.



	EU-Declaration of conformity		
	UE-Déclaration de conformité		
	EU-Konformitätserklärung		
Manufacturer	Chalmit	Address	388 Hillington Road, Glasgow. G52 4BL Scotland UK
Product	238 Wellglass Luminaire.		
EC - Type Examination Certificate	Baseefa08ATEX0177		
Notified Body	SGS FIMKO OY 0598		
ATEX Coding	II 2 GD	ATEX Classification	Group II Category 2 GD
Equipment Coding	Ex de IIB T* Gb, Ex tb IIIC T135°C Db IP6X (-50°C to +°C)		
Ingress Protection	IP66		
The technical basis, with respect to equivalence of			
La base technique, en ce qui concerne l'équivalence de			
Die technische Grundlage hinsichtlich der Normen			
Protection Standards EN 60079-0, EN 60079-1, EN 60079-7, EN 60079-31.			
Area Classification EN 60079-10-1 and EN 60079-10-2			
of compliance with the EHSRs is valid as there are no changes which materially affect the state of technological progress of the product.			
en conformité avec les EESS est valide puisqu'il n'y a aucun changement qui affecte matériellement l'état de l'évolution technologique du produit.			
zur Erfüllung der GSGA ist gegeben, da keine Änderungen erfolgt sind, die einen Einfluss auf den technischen Stand des Produkts haben.			
Terms of the directive:		Standard & Date Certified to	Standards Date Declared to
Prescription de la directive:		Standard & date certifiée à	Normes date Déclaré
Bestimmungen der Richtlinie:		Standard & Datum Zertifiziert nach	Standards Datum erklärt
2014/34/EU	Equipment and protective systems intended for use in potentially explosive atmospheres.	EN 60079-0: 2012	
		EN 60079-1: 2007	2014
2014/34/UE	Appareils et les systèmes de protection destinés à être utilisés en atmosphères potentiellement explosibles.	EN 60079-7: 2007	2015
		EN 60079-31: 2008	2014
2014/34/EU	Geräte und Schutzsysteme zur bestimmungsgemäßen Verwendung in explosionsfähigen Bereichen.		
2014/30/EU	Electromagnetic compatibility	EN 55015 : 2013	
2014/30/UE	Compatibilité électromagnétique	EN 61547 : 2009	
2014/30/EU	Elektromagnetische Verträglichkeit	EN 61000-3-2 : 2014	
2014/35/EU	Low voltage equipment	EN 60598-1 : 2015	
2014/35/UE	Équipements électriques à bas voltage	EN 60529 : 1992	
2014/35/EU	Niederspannungsgeräte / -systeme	EN 60598-2-5 : 2015	
2012/19/EU	Waste of electrical and electronic equipment		
2012/19/UE	Déchets d'équipements électriques et électroniques		
2012/19/EU	Entsorgung der elektrischen und elektronischen Geräte / Systeme		
2011/65/EU	RoHS II Directive		



On behalf of the Chalmit, I declare that, on the date the equipment accompanied by this declaration is placed on the market, the equipment conforms to all technical and regulatory requirements of the above listed directives.

En tant que représentant du fabricant Chalmit, je déclare qu'à la date où les équipements accompagnant cette déclaration sont mis sur le marché, ceux-ci sont conformes à toutes les dispositions réglementaires et techniques des directives énumérées ci-dessus.

Hiermit bestätige ich, im Namen von Chalmit, dass am Tag der Lieferung des Produkts/der Produkte zusammen mit dieser Erklärung das Gerät/die Geräte alle technischen und regulativen Anforderungen der oben aufgeführten Direktiven erfüllt.

Name and Date Mark Poutney 01/01/2021
Nom et Date
Name und Datum

Technical Manager
Directeur technique
Technischer Leiter

Quality Assurance Notification by: **SGS FIMKO OY**
Notification d'assurance qualité par: **0598**
Qualitätssicherungsnotifikation durch:

Quality Management System Accreditation:
Système de Management Qualité Accréditation:
Qualitätsmanagementsystem Akkreditierung:
Environmental Management System.
Système de gestion de l'environnement.
Umwelt kontroll system.
Certificate No./Certificat N°/Zertifikat Nr.

ISO 9001

ISO 14001
by/par/durch
Lloyd's Register
LRQ 4005876